

# System Planner for the MultiExchange Unit MXU2000R

for the Iridium<sup>®</sup> Communications System



*Connecting local systems to the world.*

Motorola and  are registered trademarks of Motorola, Inc. Iridium and the Iridium logo are registered trademarks and service marks of Iridium Satellite LLC.  
©2002 IDL Corporation. All rights reserved. Product appearance and specifications subject to change without notice.

All information contained herein is subject to change without notice. Motorola makes no warranty, implied or expressed, concerning the information contained herein, nor does IDL Corporation assume any liability or damage arising out of the application of or use of the information or products described herein.

Version 6.1  
Feb 04 02

# MXU System Planner

## Table of Contents

<b>1.0</b>	<b>OVERVIEW</b> .....	<b>1</b>
<b>2.0</b>	<b>ACRONYMS AND DEFINITIONS</b> .....	<b>1</b>
<b>3.0</b>	<b>APPLICATIONS</b> .....	<b>2</b>
<b>4.0</b>	<b>MXU SYSTEM</b> .....	<b>3</b>
4.1.	<b>Description</b> .....	<b>3</b>
4.1.1.	MXU-Terminated Calls (Inbound calls to the MXU from the Iridium constellation).....	3
4.1.2.	MXU-Originated Calls (Outbound Calls to the Iridium constellation).....	5
4.2.	<b>Equipment</b> .....	<b>6</b>
4.2.1.	Console.....	6
4.2.2.	Front Panel.....	6
4.2.3.	Back Panel.....	7
4.2.4.	Antennas and Mast.....	8
4.2.5.	Control Program.....	8
4.2.6.	Control Terminal.....	8
<b>5.0</b>	<b>INSTALLATION</b> .....	<b>9</b>
5.1.	<b>Overview</b> .....	<b>9</b>
5.2.	<b>Console Mounting</b> .....	<b>9</b>
5.3.	<b>Antenna Placement</b> .....	<b>10</b>
5.4.	<b>Interconnections</b> .....	<b>10</b>
5.5.	<b>Distance between Console and Antennas</b> .....	<b>11</b>
<b>6.0</b>	<b>OPERATION</b> .....	<b>12</b>
6.1.	<b>Provisioning</b> .....	<b>12</b>
6.1.1.	Gateways.....	12
6.1.2.	Service Providers.....	12
6.1.3.	SIM Cards.....	12
6.2.	<b>User Interface</b> .....	<b>13</b>
6.3.	<b>Initialization/Configuration</b> .....	<b>13</b>
6.4.	<b>Call Detail Records</b> .....	<b>14</b>
6.5.	<b>Operation</b> .....	<b>14</b>
6.5.1.	MXU-Terminated Calling Scenario (Calls to the MXU from Iridium constellation).....	14
6.5.2.	MXU-Originated Telephone Calling Scenario (Outbound Calls to Iridium constellation).....	15
6.5.3.	MXU-Terminated Data Calling Scenario (Calls to the MXU from Iridium constellation).....	16
6.5.4.	MXU-Originated Data Calling Scenario (Outbound Calls to Iridium constellation).....	16
6.6.	<b>Figure 4.1.2-1. Diagnostics</b> .....	<b>167</b>
<b>7.0</b>	<b>SPECIFICATION</b> .....	<b>17</b>
<b>8.0</b>	<b>ORDERING INFORMATION</b> .....	<b>18</b>

**List of Figures**

Figure 1.0-1. MXU ..... 1

Figure 4.1-1. MXU System Diagram..... 3

Figure 4.1.1-1. MXU System Diagram – MXU Terminated Calls ..... 4

Figure 4.1.1-2. Sample Card for MXU Terminated Calls..... 4

Figure 4.1.2-1. MXU System Diagram – MXU Originated Calls ..... 5

Figure 4.1.2-2. Sample Card for MXU Originated Calls ..... 5

Figure 4.2.1-1. MXU Console..... 6

Figure 4.2.1-2. Front Panel, MXU ..... 6

Figure 4.2.1-3. Back Panel, MXU ..... 7

Figure 5.1-1. Typical MXU Interconnection ..... 9

Figure 5.2-1. Typical MXU Console Installation ..... 10

Figure 5.3-1. Antenna Location..... 10

Figure 5.5-1. Typical Cable, Lengths, and Types ..... 11

Figure 6.1-1. MXU Provisioning Relationships..... 12

Figure 6.2-1. MCM Graphics User Interface (GUI)..... 13

Figure 6.5.1-1. MXU Terminated Calling Scenario ..... 15

Figure 6.5.2-1. MXU Originated Calling Scenario..... 16

### 1.0 Overview

The MultiExchange Unit MXU, shown in Figure 1.0-1 is a multi-channel, fixed product designed to provide Iridium Satellite communications for groups of users. While the Iridium handset provides excellent portability, the MXU affords other advantages such as interface to existing user phone equipment and use inside a building or structure. It allows people to take advantage of shared resources where a group of users are located in one general location -- such as in an office, a village, and hotel or on board an offshore platform. The physical layout of the MXU, with remote antennas, allows it to be used in a building, providing convenient out-of-the-weather communications.



Figure 1.0-1: MXU

The MXU is available in a 4-channel configuration, providing up to four simultaneous phone calls per unit over the Iridium constellation. It can support a large group of users depending on various traffic models and call patterns per application.

One of the main advantages of the MXU is its ability to be connected to a Private Branch Exchange (PBX) or Public Switched Telephone Network (PSTN). This lets users talk on their existing telephone equipment in offices or on an offshore platform. The MXU is great for use in areas where there are unreliable PSTN lines or no PSTN lines. IT can serve as a backup communications system in the event of crisis or disaster.

When it is necessary to make an Iridium call, the call can be placed using a standard telephone. The fact that the call goes through the Iridium constellation should not be readily apparent to users once they have dialed the access number. The MXU is essentially bridging a local PBX/PSTN system to the rest of the world by bringing a call from the outside into the PBX/PSTN. The MXU provides the same call processing features and quality as the hand held Iridium phones.

The MXU system includes four remote antennas, four coaxial cables, the MXU unit, an installation manual, and a user manual. Call processing is accomplished through L-Band Transceivers (LBT) -- one for every voice/data channel installed as part of the MXU. The MXU controller automatically routes calls to an open channel.

The MXU supports data calls using an RS-232 interface to a computer and provides 2.4K throughput (with compression, speeds up to 10K can be achieved). Data calls can be placed to or received from another Iridium satellite unit or a modem connected to a PSTN phone line. It does not support data calls through the connected PBX phone line.

### 2.0 Acronyms and Definitions

CDR	Call Detail Record
CD ROM	Compact Disk Read Only Memory
CFB	Call Forward on subscriber Busy
DTMF	Dual Tone Multi-Frequency

## MXU System Planner

ISU	Iridium Subscriber Unit
LBT	L Band Transceiver
LEO	Low Earth Orbit
ISDN	Integrated Service Digital Network
MCM	MXU Configuration Management
MSISDN	Mobile Service Integrated Service Digital Network
MXU	MultiExchange Unit
PBX	Private Branch Exchange
PC	Personal Computer
PSTN	Public Switched Telephone Network
SIM	Subscriber Identity Module

### 3.0 Applications

The Motorola MXU enables:

- Shared use of up to four Iridium channels by multiple users who communicate by means of a PBX or isolated PSTN; and
- Dedicated use of up to four Iridium data channels which communicate with a computer connected via the RS-232 interface.

The fundamental characteristics of a system that can accomplish this are:

*Adaptability* – The MXU supports various international telephone standards for 2-wire analog telephones and can be configured to the specific needs of the owner/operator.

*Accessibility* – Anyone who knows the PBX extension number of the MXU and has an account identification number can make an MXU originated call. Anyone who knows the MSISDN of the MXU can access the PBX and its end users.

*Accountability* – The MXU verifies identification of the PBX caller, preauthorizes MXU-originated calls, tracks time use, and creates call detail records.

These characteristics enable the MXU to serve numerous applications based on providing backhaul capability for PBX-equipped, wire line-isolated facilities, remote village PSTNs, and temporary emergency response facilities. It also provides backup for priority communications for 911 centers or diplomatic embassies. Calls made to other Iridium MXUs or subscriber terminals use no terrestrial communication lines; therefore, providing significantly better call security than most terrestrial communications.

Another significant application is data communications backup. By providing an independent data communications capability, the MXU provides a means to collect data from remote telemetry units such as compressor monitors, leak detection and security monitoring systems. Additionally, it can be used to provide backup data capabilities allowing users to retrieve email, access the internet, or connect to other data centers should their primary communications medium be out of service.

Optionally, the MXU application software allows user setup to track accumulated call minutes used by each account holder, and creates call detail records (including destination number called) for each voice call made. These features allow the MXU operator to implement preauthorization and post-processing of call detail records. This enables the MXU to be tailored to both business and social needs of Iridium communications users attached to a PBX. The MXU effectively manages its resources so that failure of PBX lines or Iridium channels (transceivers) should have no impact on users other than capacity reduction (as long as there is at least one of each resource operating).

## 4.0 MXU System

### 4.1. Description

The MXU system diagram, Figure 4.1-1, illustrates the following interactions:

- Private Branch Exchange (PBX)
- MultiExchange Unit (MXU)
- Local Control Terminal – Allows initialization, configuration, and control of the MXU over a local serial RS232 port.
- Satellite Constellation – Consists of Low Earth Orbit (LEO) satellites.
- Gateway – Controls the Iridium network and connects constellation-routed calls to the PSTN connected to the Gateway.
- PSTN – Routes telephone calls between the Gateway, local telephones connected to the PSTN, and cellular telephone networks. In addition, the PSTN can route calls between an MXU and telephones or between telephones and a PBX.
- Iridium Subscriber Units (ISU) – Iridium portable handsets/telephones.
- Iridium Pagers

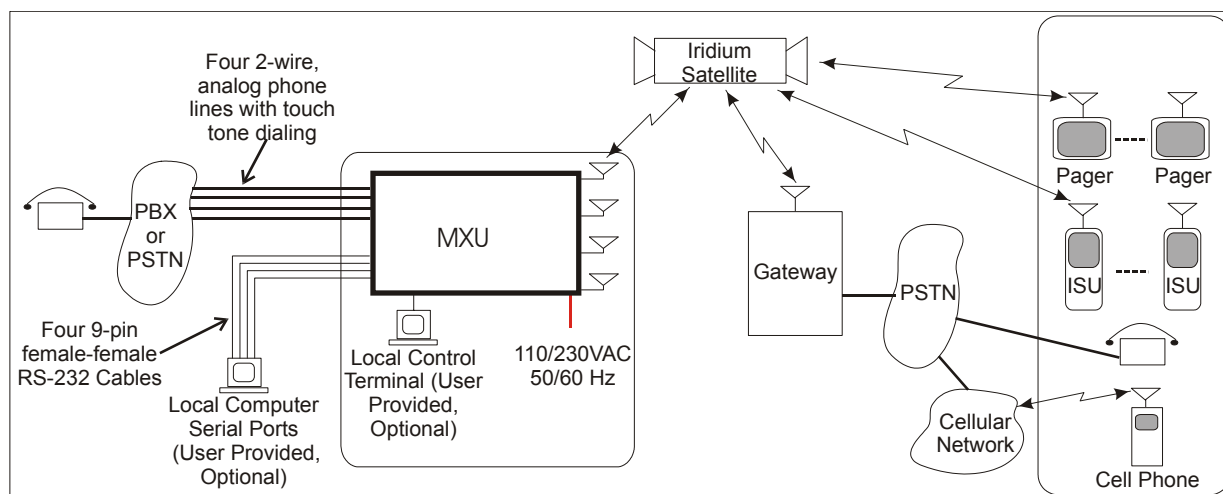

Figure 4.1-1: MXU System Diagram

The MXU provides four channels of Iridium-based, global voice communication services. The MXU attaches to the local PBX or PSTN using four standard, two-wire, analog phone lines. To the PBX/PSTN, the MXU appears as four additional phone lines. If necessary, a phone line emulator such as those available from Viking, can provide dial tone for the MXU. The phone line emulator allows you to connect a cordless or analog telephone to the MXU. Additionally, four RS-232 serial cables can be connected to computers for data communications.

**Note:** Digital phone lines are not compatible; tone dialing is required.

#### 4.1.1. MXU-Terminated Voice Calls (Inbound calls to the MXU from Iridium constellation)

A call placed from an ISU, or a PSTN telephone, to the MXU through the Iridium constellation, See Figure 4.1.1-1, requires dual-stage dialing as indicated in the card illustrated in Figure 4.1.1-2 and described below.

## MXU System Planner

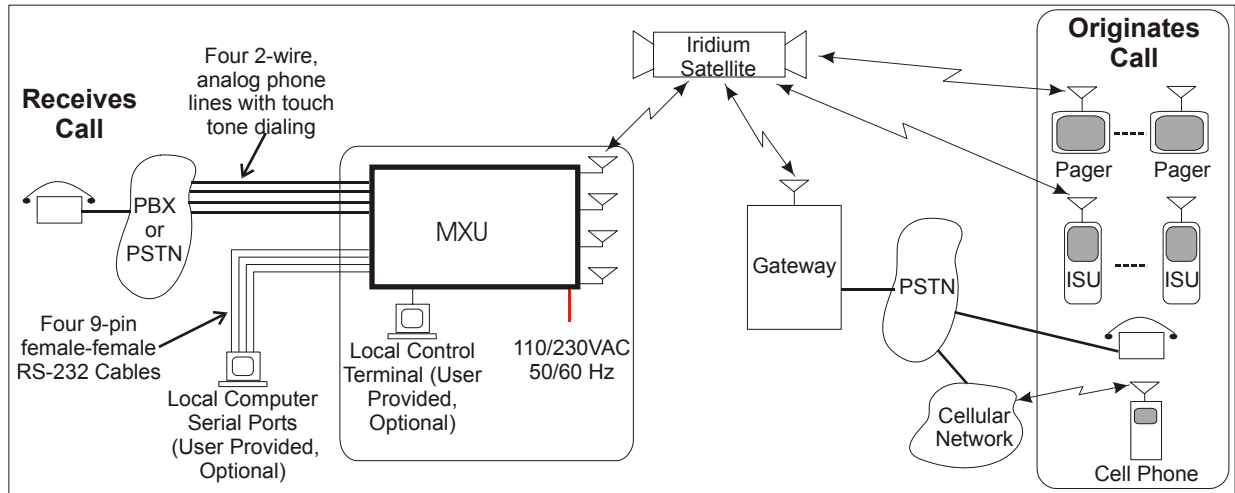

Figure 4.1.1-1: MXU System Diagram – MXU Terminated Calls

**MXU Terminated (From ISU or Telephone)  
CALL PLACEMENT PROCEDURE**  
Phone --> MXU --> Phone Extension

**1. Dial MXU Number** \_\_\_\_\_  
Listen for tone

**2. Dial Extension** \_\_\_\_\_

Figure 4.1.1-2: Sample Card for MXU Terminated Calls

This type of card could be used to list the MXU numbers when calling via the Iridium constellation. The process of calling the MXU is as follows:

- The caller dials the MSISDN of the MXU.
- If the MXU channel is available, the MXU opens the channel and issues a dial tone. The call then becomes billable. If the MXU number is busy and if the MXU SIMs are configured to call forward, the Iridium system will call the next MXU MSISDN automatically.
- The caller will hear a dial tone and dial the destination PBX extension.
- The MXU rings the destination phone.
- The caller will hear the tones from the receiving party phone system and will continue the call.

For further details, see Section 6.5.1.

**4.1.2. MXU-Originated Calls (Outbound Calls to the Iridium constellation)**

A call placed from an office phone or remote phone system tied to the PBX/PSTN side of the MXU, see figure 4.1.2-1 requires a three-stage dialing procedure to place a call through the Iridium constellation as indicated in the card illustrated in Figure 4.1.2-2 and described below.

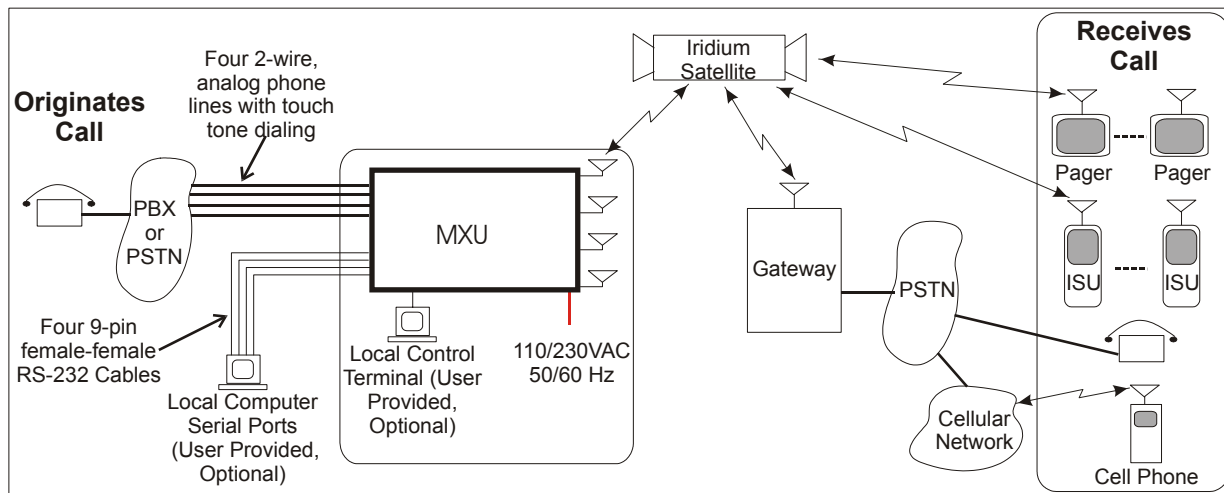

Figure 4.1.2-1: MXU System – MXU Originated Calls

**From PBX Telephone, MXU Originated  
CALL PLACEMENT PROCEDURE**  
Off. Ph. → PBX → MXU → User ID → Destination

**1. Dial MXU Number** \_\_\_\_\_  
Listen for tone

**2. Enter user ID #** \_\_\_\_\_  
Listen for Dial Tone

**3. For Long Distance/Int'l Calls** 00 \_\_\_\_\_

Figure 4.1.2-2: Sample Card for MXU Originated Calls

This type of card could be used to list the MXU numbers when calling the MXU from the PBX/PSTN to the Iridium constellation. The process of calling the MXU is as follows:

- The local PBX/PSTN caller dials the MXU extension or access number.
- The MXU opens a channel and issues a DTMF tone signaling the caller to enter an account number or personnel identification number (PIN). (**NOTE:** The account number request option is not enabled by default. The MXU owner will need to enable and set the account numbers using the MCM, if the owner desires to limit or track MXU usage.)
- When the caller enters a valid account number, the MXU issues a dial tone signaling the caller to enter the international destination phone, pager, or ISU number.
- The MXU connects to the destination number through the Iridium constellation. The call becomes billable when the destination number goes off hook.

For further details, see Section 6.5.2.

## 4.2. Equipment

The main components of the MXU, which include the console, front and back panels, are discussed below.

### 4.2.1. Console

The MXU console is illustrated in Figure 4.2.1-1. The console is mountable in a standard 19-inch rack. It can be mounted in either a vertical or horizontal position, providing there is enough clearance to access the cable, connections and buttons. **(NOTE:** Do not bend cables beyond their tolerances as this may break the cable and prevent the MXU from operating correctly). Console dimensions are 19"Wide x 20"Deep x 7"High.



Figure 4.2.1-1: MXU Console

### 4.2.2. Front Panel

The front panel is shown below in Figure 4.2.2-1.

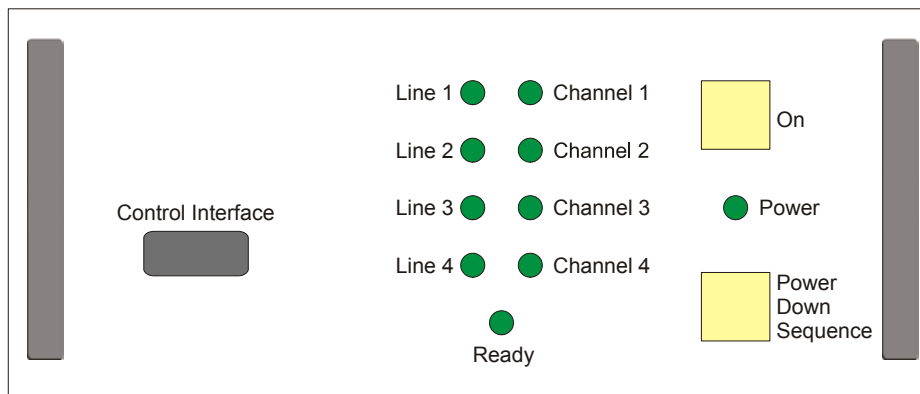

Figure 4.2.2-1: Front Panel, MXU

*Control Interface* – RS232 interface allows the initialization, configuration, and control of the MXU via the serial port of any IBM-compatible personal computer (PC) running Windows NT.

*Line 1 Indicator* – Illuminated when Line 1 attached to the PBX is active.

*Line 2 Indicator* – Illuminated when Line 2 attached to the PBX is active.

*Line 3 Indicator* – Illuminated when Line 3 attached to the PBX is active.

*Line 4 Indicator* – Illuminated when Line 4 attached to the PBX is active.

*Ready Indicator* – Illuminated when the MXU has passed the power-on diagnostics. When illuminated, the MXU has determined that a minimum of one phone line and one Iridium RF connection is active.

*Channel 1 Indicator* – Illuminated when a call is in process over LBT 1.

## MXU System Planner

*Channel 2 Indicator* – Illuminated when a call is in process over LBT 2.

*Channel 3 Indicator* – Illuminated when a call is in process over LBT 3.

*Channel 4 Indicator* – Illuminated when a call is in process over LBT 4.

*Power Indicator* – Illuminated whenever the MXU is powered on.

*On Button* – Turns the MXU on. The power indicator lights immediately; however, because the MXU is running self-tests, there will be a delay of 2 to 5 minutes before the ready indicator light comes on.

*Initiate Power-down Sequence Button* – Instructs the MXU to power down. The power indicator will start blinking; however, there is a delay of approximately 2 to 5 minutes from the time the button is pushed until the power light goes out. This is because the microprocessor is processing data and storing it on the hard drive internal to the unit.

### 4.2.3. Back Panel

Connections and access panel on the back are shown in Figure 4.2.3-1.

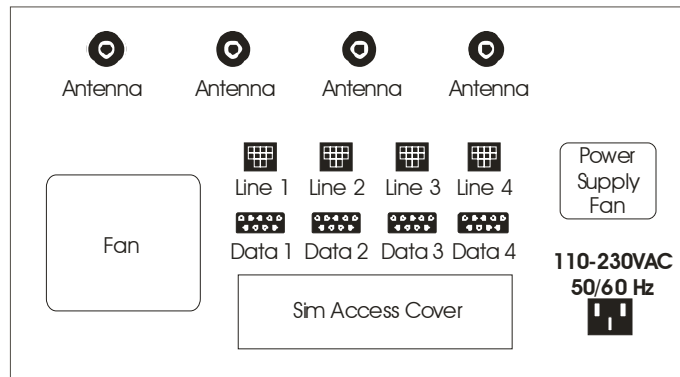

Figure 4.2.3-1: Back Panel, MXU

*Antenna 1 Connector* – Connects MXU internal LBT to antenna located outside building.

*Antenna 2 Connector* – Connects MXU internal LBT to antenna located outside building.

*Antenna 3 Connector* – Connects MXU internal LBT to antenna located outside building.

*Antenna 4 Connector* – Connects MXU internal LBT to antenna located outside building.

*Line 1 Connector* – RJ11 connector from MXU to local PBX.

*Line 2 Connector* – RJ11 connector from MXU to local PBX.

*Line 3 Connector* – RJ11 connector from MXU to local PBX.

*Line 4 Connector* – RJ11 connector from MXU to local PBX.

*Data 1 Connector* – 9-pin RS-232 male connector from MXU to serial port.

*Data 2 Connector* – 9-pin RS-232 male connector from MXU to serial port.

*Data 3 Connector* – 9-pin RS-232 male connector from MXU to serial port.

*Data 4 Connector* – 9-pin RS-232 male connector from MXU to serial port.

*SIM Access Cover* – Permits access to the four Subscriber Identification Modules (SIM).

*110/230 Vac, 50/60 Hz Connector* – External ac power connector, autoswitchable.

### 4.2.4. Antennas and Mast

One antenna is required per channel that is being used. Therefore, if you plan to use four channels will require four antennas. Antenna separation must be a minimum of 3 feet. Antennas also must have a clear view of the sky (8° above the horizon in all directions) (see Section 5) to see the satellite.

### 4.2.5. Control Programs

The MXU can be initialized, configured, and controlled by remote or local control terminals as illustrated in Figure 4.1-1. For remote control and monitoring of MXU functions, the signal path is through a user provided remote control terminal and modem, through the PBX, to the MXU. For local control and monitoring of MXU functions, the signal path is through a user provided local terminal, through the user provided RS232 null modem cable, to the MXU.

A CD ROM will be supplied with each MXU. It has loaded on it the initialization, configuration, and control program. The program can be run from the local or remote terminals.

During initialization, the control program generates an access password for the MXU. This password ties the control terminal to the MXU (remote or local). Other terminals then cannot be used as a remote terminal due to this password tie with the MXU. The control terminal should have the Windows NT's password (the one the user types in) security features enabled to prevent unauthorized access to the MXU access file.

**NOTE:** Windows NT allows several levels of passwords. The Access Control file should only be accessible by a trusted administrator.

Once the initialization program has generated the Access Control password, the MXU can only be accessed by the control program that has access to the Access Control file to retrieve the password. The user should copy the Access Control file to a floppy disk and secure it in a safe place. If this file is lost, the MXU has to be reinitialized by a program belonging to the manufacturer.

### 4.2.6. Control Terminals

The MXU is configured and controlled by local control stations as illustrated in Figure 4.1-1. The control terminals are not part of the MXU shipment and are supplied by the user. The control terminal must meet the following requirements:

- ◆ **Local**
  - *IBM-compatible personal computer*
  - *Microsoft Windows NT 4.0 with Remote Access Services (RAS) and Service Pack 3 or later*
  - *Pentium processor or equivalent*
  - *32 M RAM*
  - *10 MB of free disk space*
  - *RS232 serial port*
  - *CD ROM drive*
  - *Null modem cable (female 9-pin connector on both ends)*
- ◆ **Remote Controller:** *For the remote computer, use a Hayes compatible modem in place of the Null modem cable in the above configuration.*

## 5.0 Installation

### 5.1. Overview

An overview of the MXU interconnection is illustrated in Figure 5.1-1. The control terminal (optionally user-supplied) is connected to the front panel control port via a 9-pin null modem serial cable. The power cord from the rear panel is connected to a 115 VAC, 60 Hz or a 230 VAC, 50 Hz power receptacle. The four phone lines (two-wire analog) are connected from the rear panel of the MXU to the PBX phone jacks. Four coax antenna cables from the rear of the MXU are connected to the antennas mounted outside the building. Refer to paragraph 5.3 for locating and mounting the antennas.

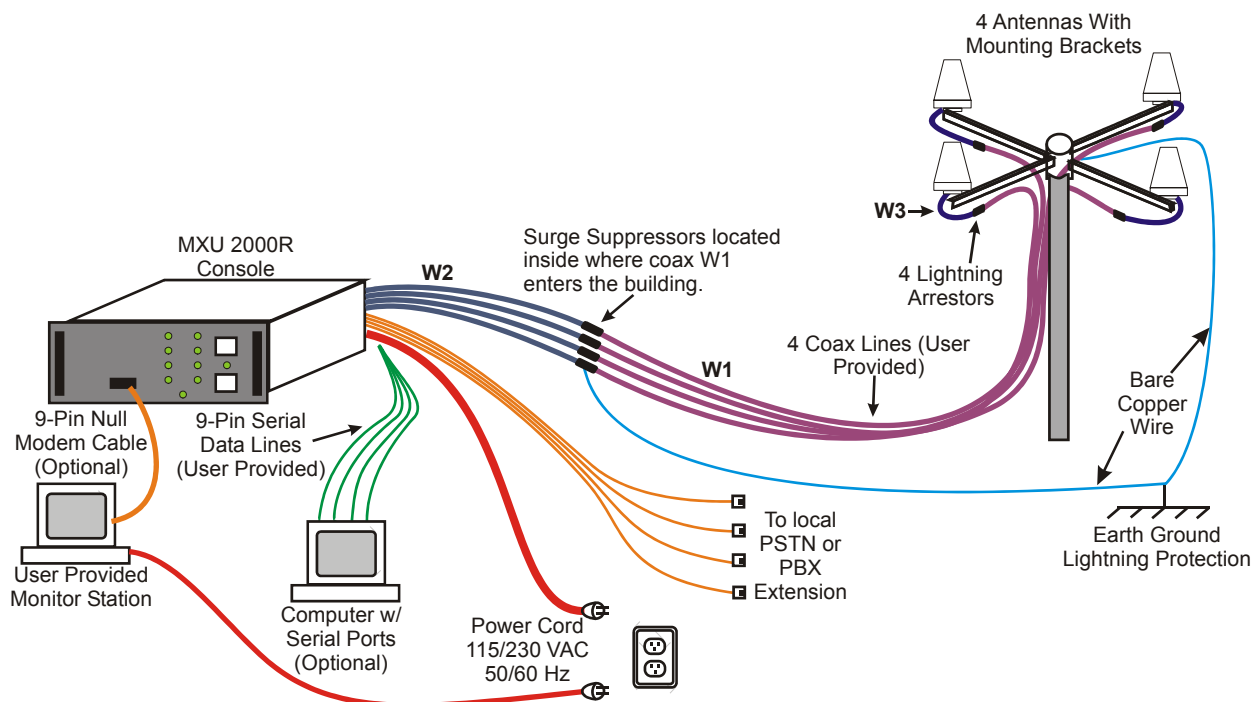

Figure 5.1-1: Typical MXU Interconnection

### 5.2. Console Mounting

The MXU console must be placed in a location where it is protected from environmental hazards such as moisture, shock, vibration, and temperature extremes (the MXU is designed for operation between 0° Celsius and +45° Celsius). Figure 5.2-1 illustrates the MXU mounted in a 19" rack.

## MXU System Planner

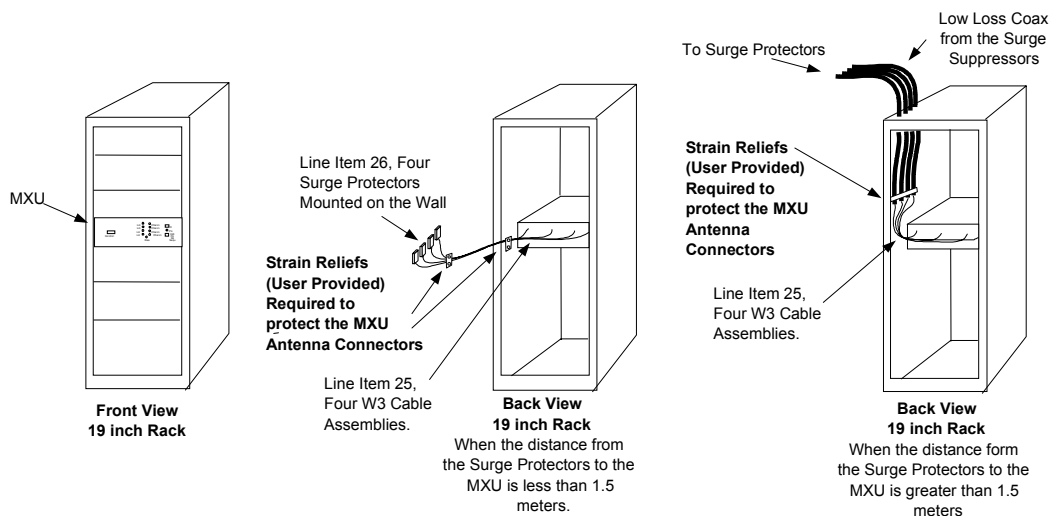

Figure 5.2-1: Typical MXU Console Installation

### 5.3. Antenna Placement

The antenna must have satellite line of site from 8° above the horizon to 8° above the horizon, as illustrated in Figure 5.3-1. The three cases illustrated are:

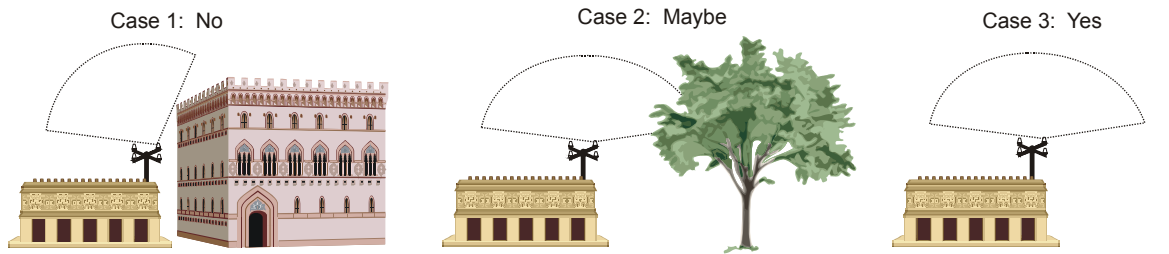

Figure 5.3-1: Antenna Location

**Case 1** – The antennas have only a partial horizon to horizon view since part of the horizon is blocked from view by a building. The MXU will not work properly.

**Case 2** – The antennas have only a partial horizon to horizon view since part of the horizon is blocked from view by a tree. The MXU may or may not work properly.

**Case 3** – The antennas have from 8° above the horizon to 8° above the horizon view in all directions. The MXU will work properly.

### 5.4. Interconnections

After installing the console and antennas per the installation manual, the interconnection of the console and antenna are as indicated in Figure 5.1-1. The following cables/wires are required:

- ◆ Surge suppressors (four included)\*
- ◆ W2 Coax (four included)\* from MXU to surge suppressor
- ◆ W3 Coax (four included) \* from antenna mounting brackets to antennas (four included)\*
- ◆ Telephone line (four included)\* from MXU to PBX outlets
- ◆ Power cord (included) from MXU to power outlet
- ◆ Bare copper wire (customer furnished) as indicated for proper grounding of the system
- ◆ W1 Coax (Customer Furnished) \* From antenna mounting bracket to the surge suppressor

## MXU System Planner

- ◆ W4 Coax (Customer Furnished) \* From surge suppressor, run internally in the building to W2

**NOTE:** If the control terminal is to be connected, a user-supplied “Null Modem Cable” is required.

### 5.5. Distance between Console and Antennas

The total insertion loss between the MXU console and the antennas must be less than 3 dB for the MXU to operate as designed. Figure 5.5-1 illustrates the standard coax configuration.

Cables W1 and W4 are customer furnished. W1 is used outside to complete the run from the antenna to the building where the surge suppressor is located. W1’s connectors are male Type N and female Type N. W4, if required due to the distance from the surge suppressor to the MXU, is used inside to complete the run to the MXU. W4 can replace (use female Type N and female TNC connectors) or connect to W2 (use male Type N and female Type N connectors). The table within the figure summarizes the maximum insertion loss allowed. The greater the length, the higher the grade cables required.

Antenna Cable	Length	Loss
W3 Antenna Strain Relief Cable	1 ft. (0.3 m) <sup>1</sup>	0.1 dB
W1 Outside RF Cable	As Needed. <sup>2</sup>	2.2 dB
W4 Inside RF Cable	Optional (depending on installation)	
W2 Inside Strain Relief Cable	5 ft. (1.8 m). <sup>1</sup>	0.5 dB
Surge Suppressor and Connectors		0.2 dB
<b>Total Maximum Loss</b>		<b>3 dB</b>

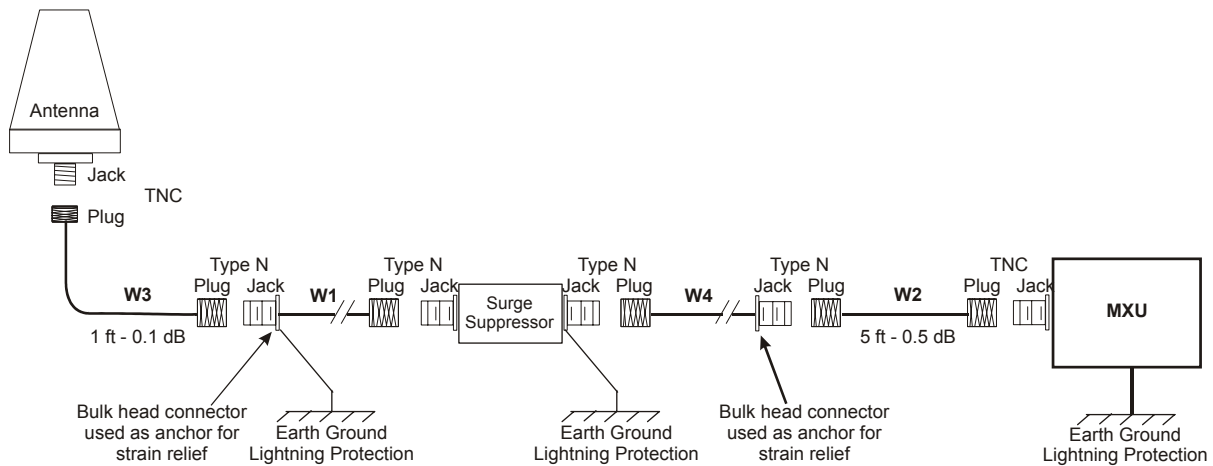

Figure 5.5-1: Typical Cable, Lengths, and Types

<sup>1</sup> Coax cable, W3, must be used in the installation to serve as strain relief, preventing damage to the connections. W2 can be used or W4 can replace W2, but you should ensure that there is no strain on the inside cables (W2 and/or W4)

<sup>2</sup> The length and type of coax used for W1 and W4 are dependent on the installation. The total loss in the cables (W1 and W4) must not exceed 2.2 dB. The cable specifications are transmission between 1616 to 1626.5 Mhz at 50 Ω impedance.

## 6.0 Operation

### 6.1. Provisioning

Figure 6.1-1 shows relationships between manufacturer, Gateways, Service Providers, and users for MXU equipment and service.

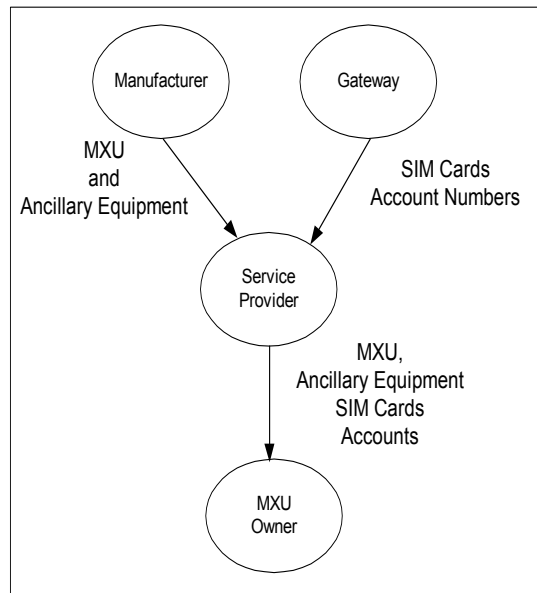

Figure 6.1-1: MXU Provisioning Relationships

#### 6.1.1. Gateways

Gateways provide interconnection between Iridium System subscribers and users of telecommunication networks such as PSTNs. Gateways also provide signaling support and management services for subscribers. Each Gateway maintains customer data for all Iridium subscribers owned by its Service Providers. The Gateway also provides support for subscribers from other Gateways and Service Providers who are roaming in that Gateway's territory. Gateways also provide SIM cards and accounting information to Service Providers.

#### 6.1.2. Service Providers

Iridium System users purchase SIM cards, MXU equipment, and service from a Service Provider.

#### 6.1.3. SIM Cards

An MXU requires four SIM cards. MXU SIM cards may be provisioned with call forwarding turned off for multi-number calling or with call forwarding turned on for single number calling. With call forwarding on, calls to a busy MXU Iridium number will be forwarded to the next Iridium MXU number. Note: The fourth MXU channel can not be forwarded to voice mail or another number.

If data will be used on the MXU, each of the SIM cards will have an MSISDN C number assigned to it. This number will be used to receive data calls through the data ports. Data cannot be used over the voice channels of the MXU.

## MXU System Planner

Refer to the MXU SIM Provisioning Guide for more information on the provisioning and configuration of MXU SIM cards.

### 6.2. User Interface

With each MXU, a compact disk is provided that has the MCM software package. This software package, along with a user provided control terminal, allows the operator to monitor and control the MXU.

The user interfaces to the MXU with the MXU Configuration Management (MCM) program that is installed on a user-supplied IBM-compatible PC (running Microsoft Windows NT 4.0 with Remote Access Services and a minimum of Service Pack 3). The program allows the MXU administrator to locally or remotely initialize, configure, and monitor MXU(s). The administrator can enable service; monitor air time use; collect Call Detail Records (CDR); and view usage, diagnostic, and error logs.

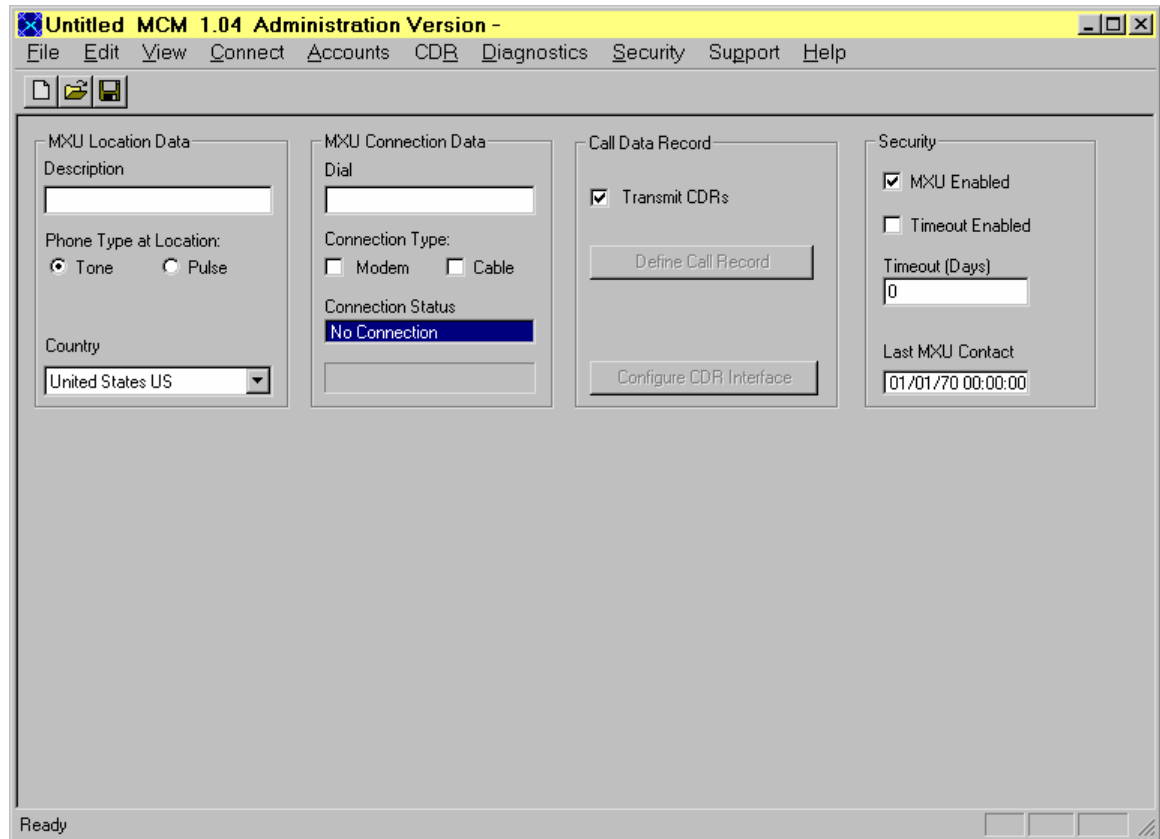

Figure 6.2-1: MCM Graphics User Interface (GUI)

### 6.3. Initialization/Configuration

The following information is required to initialize/configure a MXU:

- The phone number for each PBX telephone (**NOTE:** the phones may (or may not) be included in up to three groups for the purpose of sharing air time allocations).
- Security level required for the MXU, access numbers (PINs)
- The phone number required to access the MXU, if it is at a remote location

When the initial configuration document is first saved, the administrator must assign it a unique name. This name should be descriptive because it is displayed in the Windows **Open** dialogue box when the administrator needs to contact a particular MXU. The file must be assigned the

extension ".MXU". The file should be saved whenever a configuration is updated or saved; especially after contacting the MXU for updates or downloads. To save the file, select **File** from the menu bar and select **Save**.

During setup, the user can setup the Personnel Identification Numbers (PINs). PINs are used when an MXU originated call is made. PINs provide unit security to prevent unwanted operation and track PIN usage. From the factory, PIN input is disabled. The operator can set the PIN length from 0 (Disabled) to 7 characters.

### 6.4. Call Detail Records

The MXU gathers information (CDRs) to assist the owner with billing. Each CDR consists of the following information:

- Caller ID (Account Number)
- Called Telephone Number
- Time Stamp (Y,M,D,T) (Zulu)
- Call Duration
- Type of Connection: MXU Terminated, MXU Originated, or MXU Service
- The CDRs can be retrieved from the MXU by using the MCM software or by monitoring the data that is sent real time out the local control interface port.

### 6.5. Operation

#### 6.5.1. MXU-Terminated Voice Calling Scenario (Calls to the MXU from Iridium Constellation)

The MXU can be configured in two ways:

- Single number calling, where one MSISDN is used to call all of the MXU MSISDNs, or
- Multiple number calling where a MSISDN is used for each MXU channel.

Programming the SIM setup, as discussed in the MXU SIM Provisioning Guide, could set either option. The following addresses the usage of both options.

**For Multiple Number Calling: MXU SIM cards will return a busy signal when the MXU is in use and will only allow a channel to be direct connected to.**

A simplified scenario of a PSTN-connected phone making an MXU-terminated call is illustrated in Figure 6.5.1-1. When a call is placed from a phone connected to the PSTN, the user initiates the call by dialing one of the MXU MSISDN numbers (1). The PSTN routes the call to the Iridium Gateway which connects to the MXU (2). If the MXU is in use, the Gateway issues a busy signal to the user (3). The user will need to dial the next MXU MSISDN number.

If the number dialed is available, the MXU detects the ring (4) from the constellation/Gateway and answers the call. See "Continue for Both".

**For Single Number Calling: MXU SIM cards set to forward to the next MXU number to allow one number to call all channels of the MXU.**

A simplified scenario of a PSTN-connected phone making an MXU-terminated call is illustrated in Figure 6.5.1-1. When a call is placed from a phone connected to the PSTN, the user initiates the call by dialing the MXU MSISDN #1 (1). The PSTN routes the call to the Iridium Gateway which determines whether one of the four LBTs connected to the MXU is available (2). If no lines are available, the Gateway issues a busy signal to the user (3).

If a line is available, the MXU detects the ring (4) from the constellation/Gateway and answers the call. See "Continue for Both".

**Continue for Both**

The MXU determines if a PBX line is available (5). If a line is not available, a busy signal is returned to the user (6). If a PBX line is available, the MXU goes off hook (7) and the PBX dial tone (8) is presented to the user. The ISU user responds to the dial tone by dialing the final destination number (9). The PBX rings the destination PBX phone (10). The ring can be heard on both ends of the connection.

When the user phone goes off hook (11), the phone connection between the ISU and the PBX phone is complete, and communications can proceed (12, 13, 14, 15, 16, & 17). The MXU detects when either end hangs up (18, 19) and ends the call. (20).

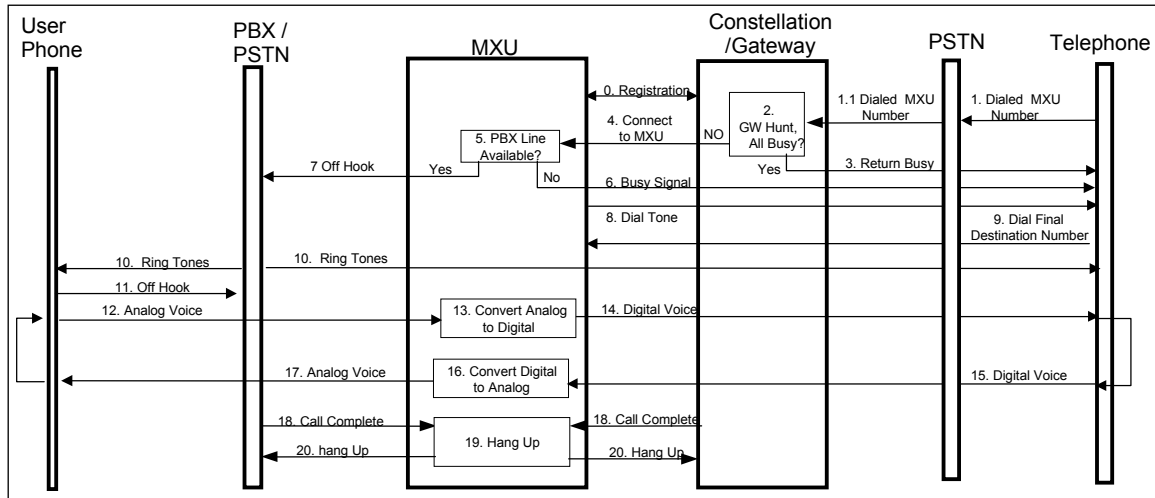

Figure 6.5.1-1: MXU Terminated Calling Scenario

**6.5.2. MXU-Originated Voice Telephone Calling Scenario (Outbound Calls to Iridium Constellation)**

A simplified scenario of a PBX-connected phone making an MXU-originated call is illustrated in Figure 6.5.2-1. The PBX user initiates a call by dialing the MXU number into the PBX (1). If the MXU extensions are not available, the PBX issues a busy signal to the user. If a line is available, the PBX rings the MXU (2). If there are no Iridium channels available, the MXU returns a busy signal.

**If the factory settings are not changed, Personnel Identification Numbers are not needed:**

If a channel is available, the MXU presents a dial tone to the user's phone (11). The user dials the destination number (12). The MXU receives the destination number (13) and establishes the call (14, 15). When the called party answers, the voice connection is complete. Communication can now commence (16, 17, 18, 19, 20, & 21). The MXU detects when the call is complete (22) and disconnects the call (23 & 24).

**When the user configures the MXU to require Personnel Identification Number Inputs:**

If a channel is available, the MXU issues a DTMF tone (6) signaling the user to enter his or her account number. The user inputs the account number (7). The MXU receives the account number from the user and checks the account to be sure that it is valid (8). If the account is not valid the MXU sends an Invalid Code ID Tone (9) to the caller and then terminates the call attempt. If the account is valid, the MXU presents a dial tone to the user's phone (11). The user dials the destination number (12). The MXU receives the destination number (13) and establishes the call (14, 15). When the called party answers, the voice connection is complete.

## MXU System Planner

Communication can now commence (16, 17, 18, 19, 20, & 21). The MXU detects when the call is complete (22) and disconnects the call (23 & 24).

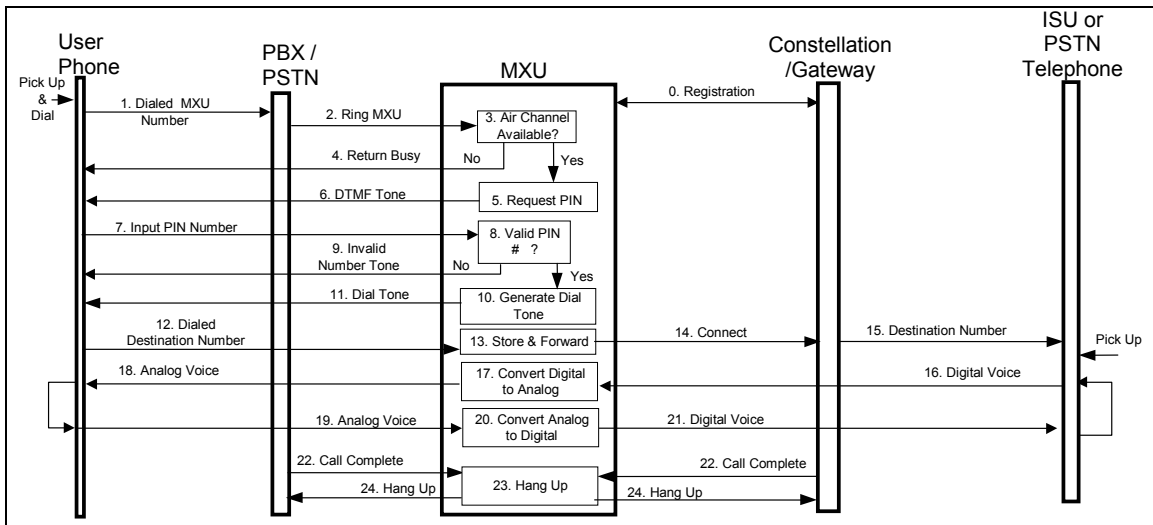

Figure 6.5.2-1: MXU Originated Calling Scenario

### 6.5.3. MXU-Terminated Data Calling Scenario (Calls to the MXU from Iridium Constellation)

The MXU can be configured with multiple number calling or with single number calling utilizing call forwarding. A MSISDN-C is used for each MXU channel.

**NOTE: MXU SIM cards return a busy signal when the MXU is in use. It only allows a channel to be direct connected only.**

**NOTE:** The MXU does not detect when a data channel is in use. Therefore an outbound voice call will cause the data channel to drop its connection. If a channel is to be used for data, it is strongly recommended that the corresponding line is not connected to the PSTN or PBX. For example, if you will accept data calls on Channel 4, you should not have the RJ11 phone line plugged into Line 4. Call forwarding from any channel to channel 4 should be disabled.

When a data call is placed from a modem connected to the PSTN or another Iridium ISU, the modem calls one of the MXU MSISDN C numbers. The PSTN routes the call to the Iridium Gateway which connects to the MXU. If the MXU is in use, the Gateway issues a busy signal to the modem. The modem will need to dial the next MXU MSISDN C number or wait and try the same number later.

If the number dialed is available, the MXU Modem detects the ring from the constellation /Gateway. The modem software used on the computer connect to the MXU should be configured to answer the call. Once the data call is answered by the user supplied computer, the connection is established between the calling device and the local computer. Any commands, data transfers, etc can be completed.

**NOTE:** Refer to the "Iridium Dial-Up Data Users Guide" for configuration of the modem and other information.

This is a brief description of how the data services work. For more detailed information refer to the "Iridium Dial-up Data User's Guide" available at [www.iridium.com](http://www.iridium.com).

### 6.5.4. MXU-Originated Data Calling Scenario (Calls from the MXU to Iridium Constellation)

The MXU can be configured with multiple number calling or with single number calling utilizing call forwarding. A MSISDN-C is used for each MXU channel.

**NOTE: MXU SIM cards return a busy signal when the MXU is in use. It only allows a channel to be direct connected only.**

**NOTE:** The MXU does not detect when a data channel is in use. Therefore an outbound voice call will cause the data channel to drop its connection. If a channel is to be used for data, it is strongly recommended that the corresponding line is not connected to the PSTN or PBX. For example, if you will initiate data calls on Channel 4, you should not have the RJ11 phone line plugged into Line 4. Call forwarding from any channel to channel 4 should be disabled.

When a data call is placed from a computer via a serial cable connected to the MXU's data port, the MXU establishes the call. When the remote computer answers, the modems will sync and the data connection is completed. The MXU will detect with the data call is complete and disconnects the call. Once the data connection is established between the MXU and the remote device, any commands, data transfers, etc can be completed.

**NOTE:** Refer to the Dial-Up Data Users Guide for configuration of the modem and other information.

This is a brief description of how the data services work. For more detailed information refer to the "Iridium Dial-up Data User's Guide" available at [www.iridium.com](http://www.iridium.com).

### 6.6. Diagnostics

By activating the "Diagnostics" pull-down menu on the control screen of the control terminal, diagnostics may be performed locally or remotely, as described below.

The **Get Diagnostic Logs** command contacts the MXU and retrieves the latest logs, which contain information on system use and system health. The **Display Diagnostic Logs** command shows the contents of the MXU logs. The administrator can display, edit, or print the files by selecting them. The **Clear Diagnostic Logs** command contacts the MXU and resets the logs to zero. (NOTE: This should only be done if advised by support personnel.)

The **Get Software Version** command contacts the MXU and displays the currently installed version numbers for software and firmware.

The **Get Error Logs** and **Display Error Logs** commands function like the **Diagnostic Logs** commands but download the error reports, if any are found at the MXU.

The **Update Software** and **Update Firmware** commands identify which version of MXU system code is included in the installed MCM program. If it is a later version than that installed on the MXU, then the later version is uploaded to the MXU.

## 7.0 Specification

Dimensions	19.0"W X 20.0" L X 7"H (48.3 cm X 50.8 cm X 17.8 cm)
Weight	25 lbs. (11.3 kg)
Operating Temperature	+32°F (0°C) to +130°F (+45°C)
Storage Temperature	-67.9°F (-20°C) to +140°F (+60°C)
Humidity	80% RH at 104°F (+40°C)
Service Life	5 years (Design Goal)
Power	115/230 VAC, 50/60 Hertz 130 W
Interface to PBX	MXU complies with CTR 21 (Europe) MXU complies with FCC Part 68 (USA)
Minimum Distance between Antennas	3 feet (.91 m)
Max loss between MXU and Antenna	3 dB loss

## **8.0 Ordering Information**

The MXU is sold only through authorized Iridium Service Providers who order it from IDL Corporation. Product availability, terms and conditions of sale are available from your Service Provider.